

INSTRUCTIONS FOR INSTALLATION OF INTERCONNECTED LOCKS IN NEW DOORS OR THE REPLACEMENT OF EXISTING LOCKS

1. MARK DOOR

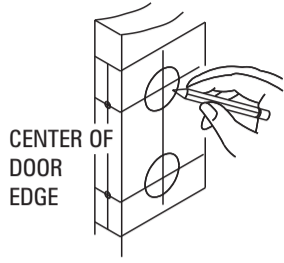

Place template on high edge of door bevel, suggested height 38" (965mm) from floor.
 On door edge, mark centers of 1" (25.4mm) holes for both top latch and bottom latch.
 Check backset of the lock you are installing, either 2.36" ± 0.02 " or 2.76" ± 0.02 " (60mm ± 0.5 or 70mm ± 0.5).
 On door face, mark centers of 2.13" ± 0.01 " (54mm ± 0.25) hole for top deadbolt and 2.13" ± 0.01 " (54mm ± 0.25) hole for bottom leverset.
(Note : Be sure to use correct backset size.)

2. DRILL HOLES

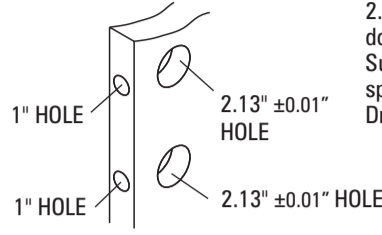

Drill 2.13" ± 0.01 " (54mm ± 0.25) hole for top deadbolt and 2.13" ± 0.01 " (54mm ± 0.25) hole for bottom leverset through door face.
 Suggest to drill holes from both sides of door face to prevent splitting.
 Drill two 1" (25.4mm) holes through centers of door edge.

3. INSTALL LATCHES

- Insert latches in holes. Latch faces must be parallel to door face. Mark latch face outline on door edge and remove latches. Chisel 0.16" ± 0.008 " (4.0mm ± 0.2) deep or until latch faces are flush with door edge. Insert latches and tighten screws securely.
- A location should be vertical there were at most 0.5mm deviation.
- Face plate will be flush with door edge after tighten the screws.

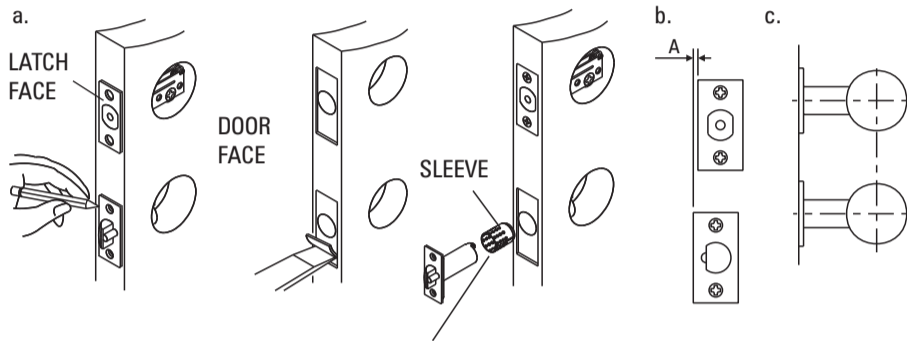

Need to add the sleeve while installing the latch.

4. INSTALL STRIKES

- Close door until latchbolts touch jamb to locate strike on jamb and center line of strike. Open door and extend line from mark to door stop. Measure one half of door thickness from door stop and vertically mark drill point center for strike.
- Drill two holes 1" (25.4mm) diameter and 1" (25.4mm) deep in door jamb.
- Place strike on jamb, centered over holes, mark outline and chisel 0.2" (5mm) for upper strike and chisel 0.08" (2mm) deep for bottom or until strikes are flush with jamb. Install strikes and tighten screws. Please be noted that for upper strike the long wood screws should install in advance as shown above.
(Note : Bottom strike has an adjustable tang can be bent in or out to eliminate loose fit between door and door stop.)

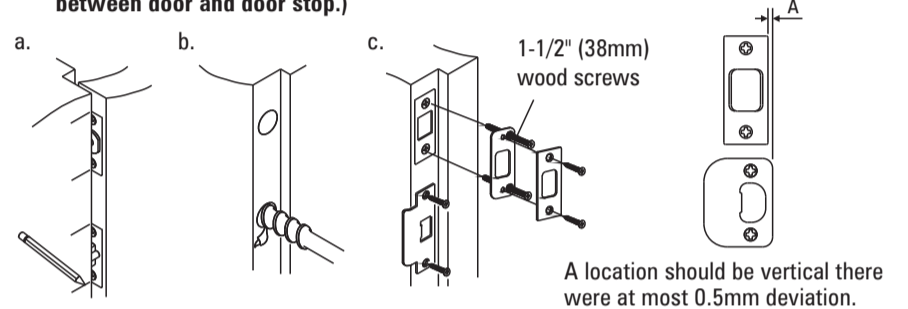

A location should be vertical there were at most 0.5mm deviation.

5. REMOVE INSIDE LEVER

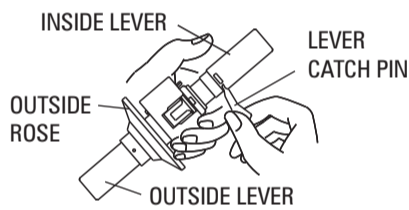

Use lever catch pin to depress lever catch visible under inside sleeve collar and slide lever off spindle.

6. ADJUST DOOR THICKNESS

Adjust door thickness by the scale gauge.

The scale gauge should be used to close to lever to measure the thickness if fit the door.

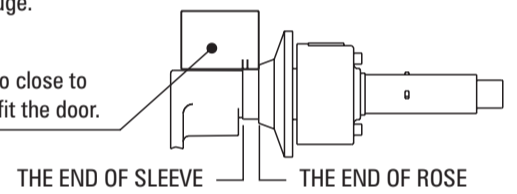

7. INSTALL LOCK ASSEMBLY

- Place outside escutcheon on exterior door face.

WARNING:
 TO AVOID UNINTERCONNECTION BETWEEN DEADBOLT AND CYLINDRICAL LOCK, MAKE SURE THAT THE LATCH BOLT OF THE UPPER DEADBOLT IS NOT PROJECTING PRIOR TO INSERT THE TAIL PIECE INTO THE LATCH HOLE HORIZONTALLY.

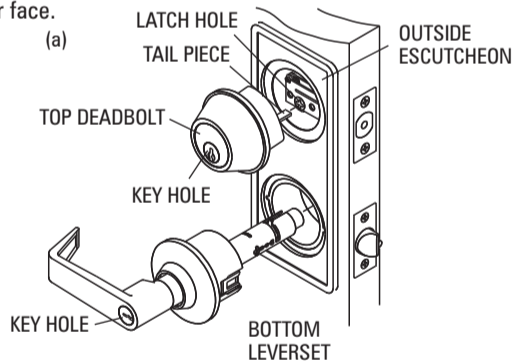

- Insert leverset into bottom latch. Latch must be in place before installing lock. Be sure to have lock housing engaged with latch prongs and also retractor engaged with latch tail.

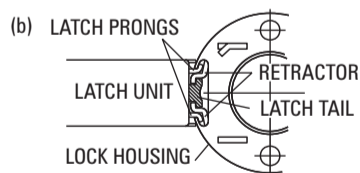

CAUTION :
 DO NOT ATTEMPT TO INSTALL LOCK WITH DOOR CLOSED

- Install deadbolt exterior keyed cylinder and guard. Be sure to insert tail piece horizontally through latch hole.



NOTE: This assembly is placed through latch hole horizontally

- Install inside lever, use pin to press down the lever catch in the hole and push inside lever all the way in until catch clicks into catch hole.

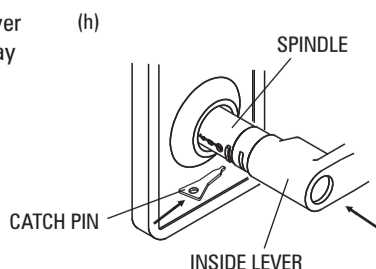

- Install inside liner, tighten installation screw of leverset and deadbolt.
- Slide inside escutcheon onto spindle of bottom lock so driver tab engages with spindle groove. Change direction of driver tab from left to right or right to left as shown in Step 8 if necessary.
- Slide tail piece of deadbolt onto turnpiece groove.
- Tighten 2 screws on inside escutcheon securely.

NOTE : The prong need to catch with the groove while tighten screws.

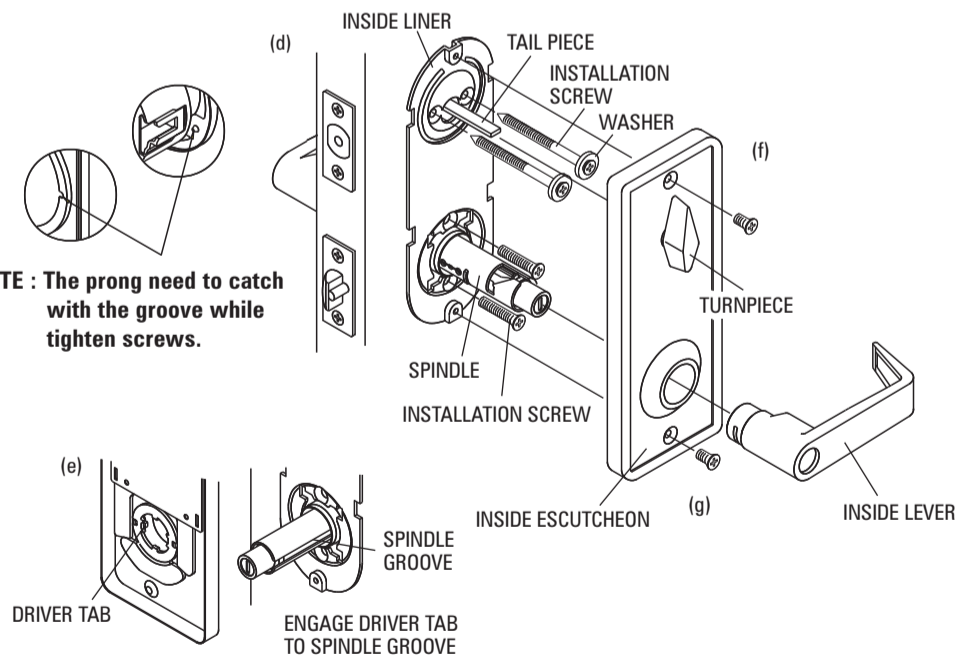

- After installation properly, inside lever just turn clockwise to retract the bolt.

