

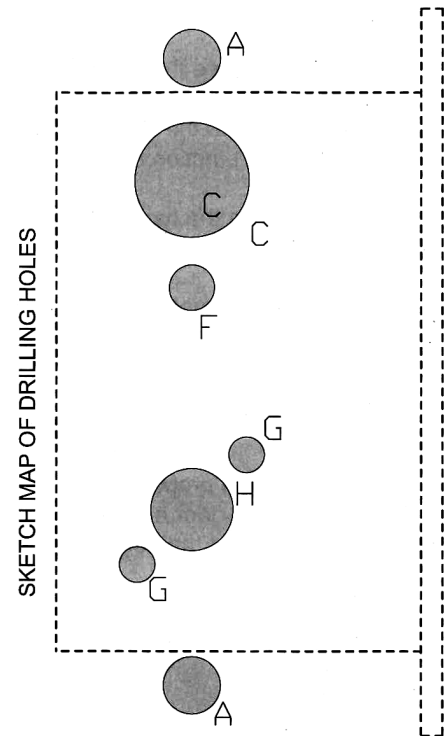

Drill holes according to the function of lock as below form.

FUNCTION \ DRILL HOLE	AB,AT,T		D, R		L		N	
	INSIDE	OUTSIDE	INSIDE	OUTSIDE	INSIDE	OUTSIDE	INSIDE	OUTSIDE
A- REGULAR/WIDE TYPE HOLES	DRILL THROUGH	DRILL THROUGH	DRILL THROUGH	DRILL THROUGH	DRILL THROUGH	DRILL THROUGH	DRILL THROUGH	DRILL THROUGH
C- CYLINDER HOLE		■		■				
F- THUMB TURN/EMERGENCY KEY HOLE	■				■	■		
G- SECTIONAL TYPE HOLE	■	■	■	■	■	■	■	■
H- LEVER SPINDLE HOLE	■	■	■	■	■	■	■	■



- * Door thickness must more than 1-3/4" (45mm).
- * Confirm the escutcheon type (sectional or regular/wide) before drilling holes. Then choose holes according to the escutcheon type.
- * Due to these holes go through the mortise lockcase, we suggest to drill the hole separately and don't drill it through.

TOOL REQUIRED

- 1.Pencil
- 2.Drilling machine and assorted drill bits, includes (1", 1/4", 7/8", 5/8", 3/8", 1/8")
- 3.3/4" wood chisel or corner chisel
- 4.Hammer
- 5.Phillips head screwdriver
- 6.Measuring device
- 7.Combination square

Left Hand

Right Hand

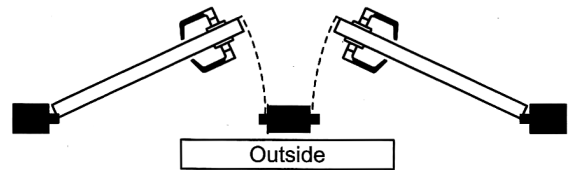

Left Hand Reverse

Right Hand Reverse

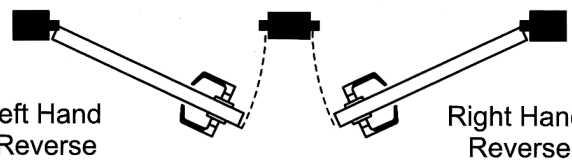

A. SECTIONAL ESCUTCHEON

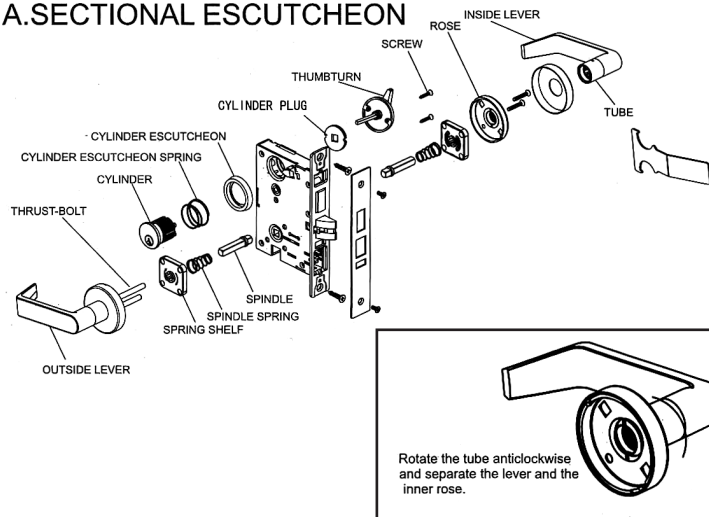

B. REGULAR/WIDE ESCUTCHEON

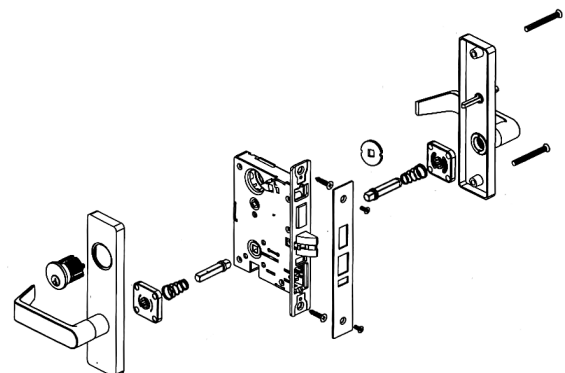

1 INSTALL CONDITION

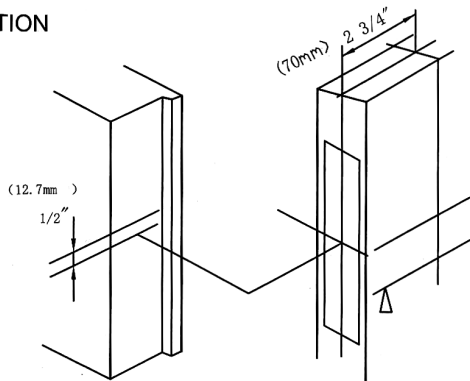

* NOTE: Before referring to this instructions, please ensure that the door reaches ANSI A1151.1 standard requirements.

1. Mark center line on both sides of the door and door edge.
2. Mark the vertical center lines on both side of the door for cylinder, knob or lever.
3. Mark the striker at 1/2" on the door frame.

2. ATTACH THE INSTALLATION TEMPLATE GUIDE

- A. Fold and attach the Installation Template Guide to the door.
- B. Mark door at appropriate locations for lock and trim.

* NOTE: Before drilling the holes, make sure that the holes need to be through or blind. Otherwise it will damage the door.

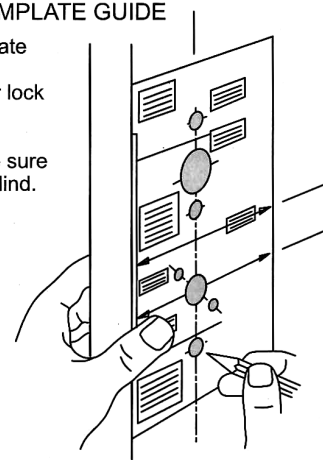

3. CUT RELIEF CAVITIES

1. Drill the cavity for lockcase on the door front according to the template, square the corners by wood chisel for the hole 6-3/4" x 1" x 4 1/4" (L x W x D)

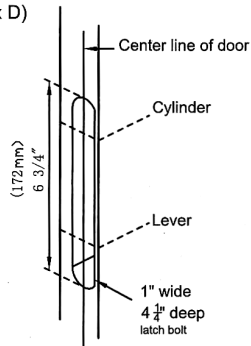

4A. SIDE HOLES (SECTIONAL TYPE)

1. Drill holes according to the function and escutcheon type of the lock. (such as drill a blind hole for cylinder and an open hole for lever on outside the door.)

* NOTE: Holes are different if the locks are with different functions. Please take attention to the specifications on the template before drilling the holes.

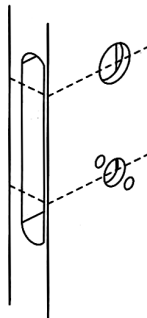

4B. SIDE HOLES (REGULAR TYPE)

1. Drill holes according to the function and escutcheon type of the lock. (such as drill a blind hole for cylinder and an open hole for lever on outside the door.)

* NOTE: Holes are different if the locks are with different functions. Please take attention to the specifications on the template before drilling the holes.

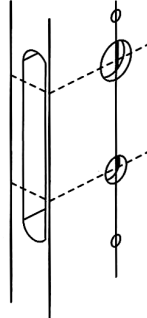

5. CUT THE GROOVE FOR THE LOCKCASE FACEPLATE

1. Use a wood chisel to square the corner Groove size: 1-1/4" x 8" x 7/32".

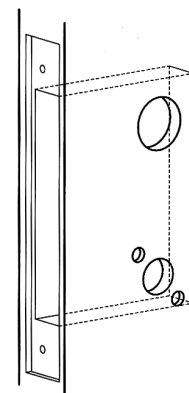

6. HANDING CHANGE INSTRUCTION (When lock direction is not tally with opening direction.)

1. Release the screw on the latchbolt, pull latch bolt out of the lock and turn by 180° and re-install into the lock and tighten the screw.
2. Turn the security card by 180°.
3. Check if the lock works properly.

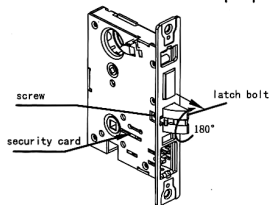

7. INSTALL THE LOCK CASE

1. Make sure the faceplate of lockcase have removed.
2. If necessary, release the screws on the top and bottom and adjust the side plate to fit the bevel door, then tighten the screws.
3. Put the lockcase into the cavity.
4. Keep the lockcase vertical and tighten the wood thread and machine thread screw on the door.

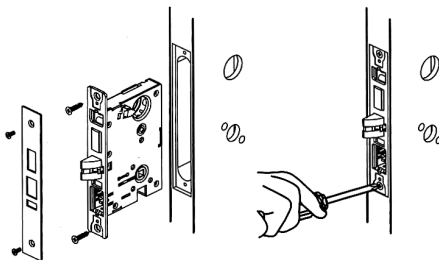

8. INSTALL THE SPINDLE

1. Insert the spindle and the spring into the cam on both sides of the lockcase.

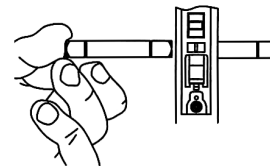

9. INSTALL THE FRONT LEVER (SECTIONAL TYPE)

1. Put the spindle spring into the square hole of the lever (as picture A)
2. Put the spring shelf into the screw bolt which on the back of the lever (as picture B)

* NOTE: Make sure the spring shelf is at the right direction as picture shown.

3. Insert the two screw bolt and the spindle into the holes and lock. Keep the front lever tight to the door.

* NOTE: Before installing, ensure the door thickness is large than 45mm. If not, cut the screw bolt to be proper length.

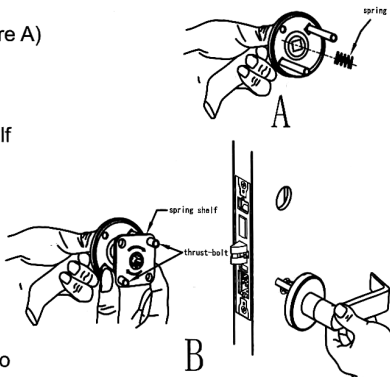

10. INSTALL THE BACK LEVER (SECTIONAL TYPE)

1. Remove the back lever first when installing the back lever. Rotate the lever tube by anti-clock direction to separate the lever and rose.
2. Insert the spring shelf into the spindle and cover the rose.

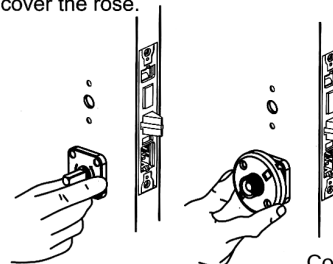

Continued on next page

10. Continued

- Fix the rose on the door by screw.
- Put the outside rose on, rotate the lever tube by the wrench supplied.

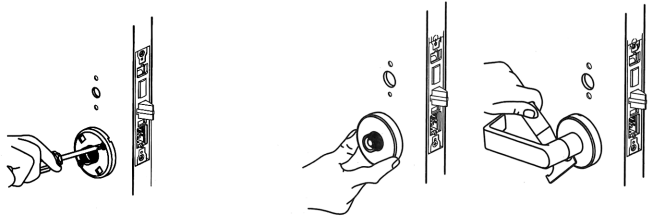

11. INSTALL THE CYLINDER

- Release the cylinder screw (as picture B).
- Turn the cylinder cam at point of 12 o'clock. Take care of the right direction of the keyway.
- Rotate the cylinder into the lockcase properly and ensure the cylinder is not too long or too short.
- Fix the cylinder by tighten screws.

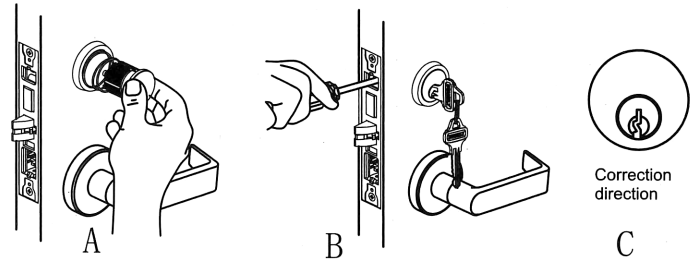

12. THUMBTURN INSTALLATION

- Insert the thumbturn through the door hole to the lockcase. Tighten the screw and fix the thumbturn on the door. Make sure that two screw is vertical.

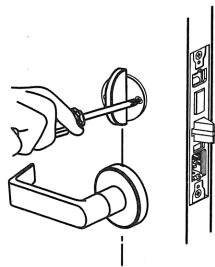

13A. INSTALL THE FRONT ESCUTCHEON AND CYLINDER (REGULAR/WIDE TYPE)

- Insert the front lever's spring shelf into the spindle (step 10).
 - Put the lever to be horizontal and push it into the spindle. Keep tight to the door.
 - Insert the cylinder across the escutcheon and rotate it easily (step 12)
- * NOTE: Lift-up the escutcheon to the right position until finishing assembling the cylinder.

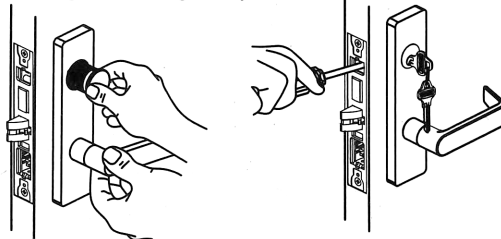

13B. INSTALL THE BACK ESCUTCHEON (REGULAR/WIDE TYPE)

- Insert the back lever's spring shelf into the spindle (step 11).
 - Put the lever to be horizontal and push it into the spindle.
- * NOTE: Ensure both escutcheon are horizontal and parallel. Lift-up the escutcheon to the right position and tighten the screw on the back escutcheon.

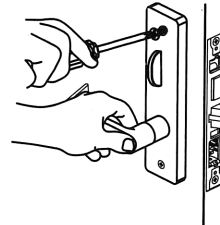

14. INSTALL THE FACEPLATE

- Fix the faceplate with the screws on the lock body.

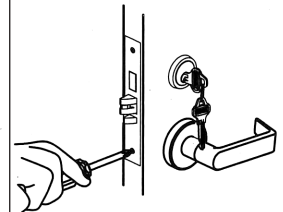

15. INSTALLING THE STRIKER

- Mark the holes and shape of the striker on the door edge according to the position of the lock case.
- Mark the groove location and square the strike box by chisel. (as picture below) Groove size: 3 3/4" X 1" X 1 1/8"
- Make a groove for striker around the strike box by chisel. Groove size: 4 7/8" X 1" X 3/32" Make a gap for the striker on the door edge. (as the picture below).

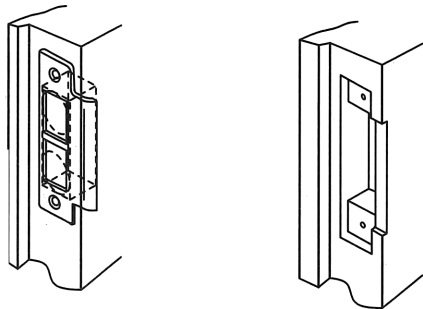

- Insert the strike box and fix the striker by screws.

* NOTE:

- When the strike box to be no need, ensure the pocket is deep enough for the deadbolt extension.
- Make sure the auxiliary latch can touch the striker to secure the latch

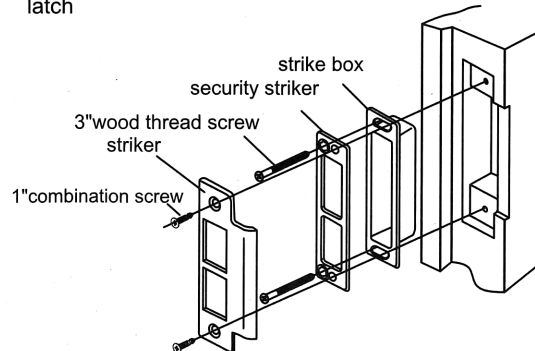

INSTALLATION INSTRUCTIONS FOR THUMBTURN

Installing thumbturn

- Rotating hex socket cap screw out of thumbturn by allen Key.
- Fasten the inside rose on the door by two ST4 x 13 screws.
- Installing the cover on the inside rose.
- Fasten hex socket cap screw of thumbturn on the spindle by allen key.

Stainless Steel Thumbturn Component List

- Thumbturn
- M4 x 6 hex socket cap screw
- Allen key
- Cover
- ST4 x 13 screw (2 pcs)
- Inside part

Exploded View - Thumbturn

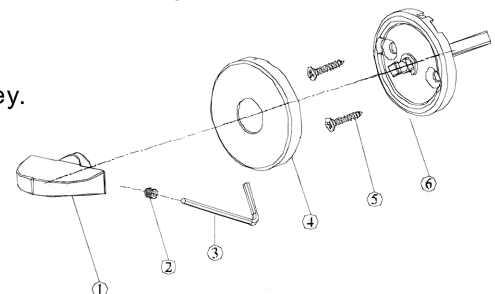

SELECT, MARK AND DRILLING HOLES

1. Please see the "hole function" form below and select the holes according to the escutcheon type and function of lock case.

2. Confirm the type of the plate (regular or sectional).

3. Stick a template on the edge of the door. Make sure the cylinder holes on the template are matched with the lock case mortise.

4. Stick the proper templates on both sides door according to the centerline of the door edge template.

5. Drill holes on the proper position.

6. Drill holes, please check 《Instruction For #7 Series Lockcase》 for reference.

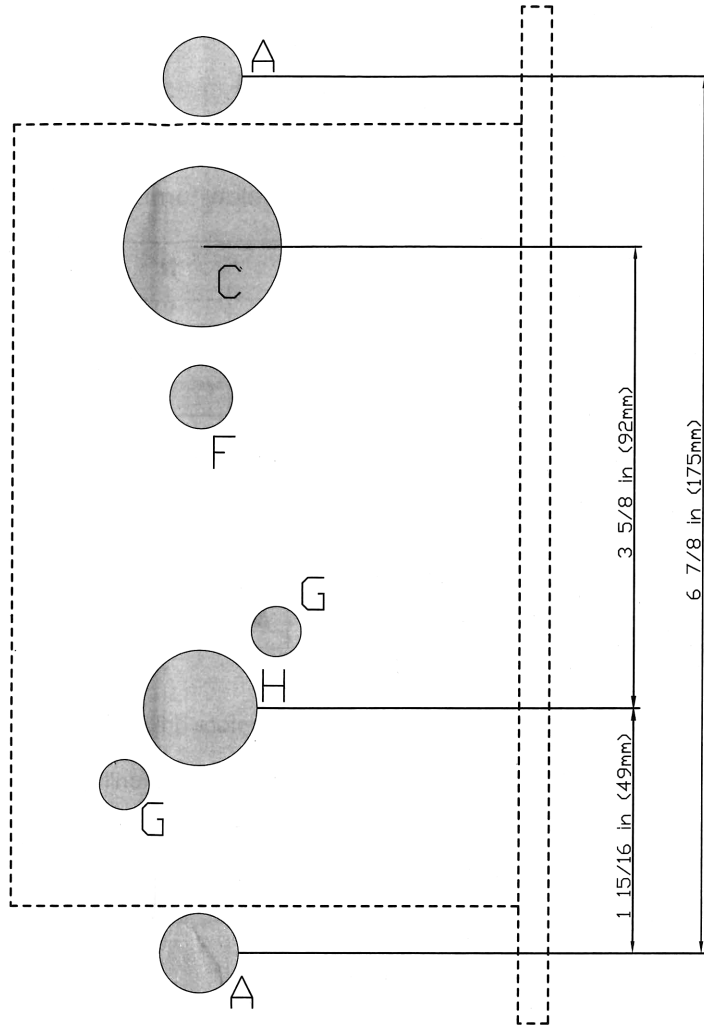

HOLE FUNCTION

FUNCTION \ DRILL HOLE	AB,AT,T		D, R		L		N	
	INSIDE	OUTSIDE	INSIDE	OUTSIDE	INSIDE	OUTSIDE	INSIDE	OUTSIDE
A- REGULAR/WIDE TYPE HOLES	DRILL THROUGH		DRILL THROUGH		DRILL THROUGH		DRILL THROUGH	
C- CYLINDER HOLE		■		■				
F- THUMB TURN/EMERGENCY KEY HOLE	■				■	■		
G- SECTIONAL TYPE HOLE	■	■	■	■	■	■	■	■
H- LEVER SPINDLE HOLE	■	■	■	■	■	■	■	■

NOTE:

- * Confirm the escutcheon type (sectional or regular/wide) before drilling holes. Then choose holes according to the escutcheon type.
- * Due to these holes go through the mortise lockcase, we suggest to drill the hole separately and don't drill it through.